

Neles™ high performance metal seated Neldisc™ triple eccentric disc valve

Series L12

Neles Neldisc series L12 a wafer type, metal seated high performance triple eccentric disc valve. With close to equal percentage characteristics and superior tightness, Neldisc triple eccentric disc valves operate both in control and shut-off applications.

As a result of the unique geometry of Neldisc, the contact between disc and seat is mechanically induced and does not rely on assistance from differential pressure. The valve is very tight even in low Δp applications.

Due to a number of special constructions developed from the versatile Neldisc design, these valves offer a powerful tool for standardization and are true high performance valves.

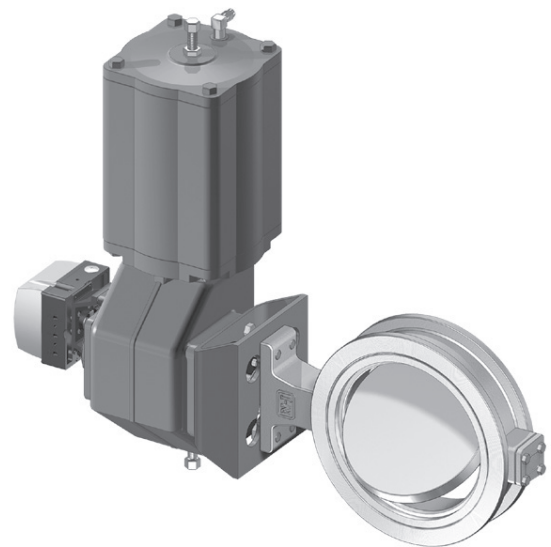

Sizes and pressure ratings

- Size range DN 80 - 1400, 3" - 56".
- Pressure ratings PN 10, 16, 25 and ANSI 150.

Features

- Metal-to-metal seated Neldisc triple eccentric disc valve.
- Designed especially for paper and pulp applications.
- Light weight – easy to install.
- Compact overall design with minimal space demand.
- Can be mounted between all common pipe flanges.
- Two-shaft construction and seat located in the body groove give high flow capacity and minimum flow resistance.
- Excellent tightness by using the renowned Neldisc seating principle.
- Bidirectionally tight construction where seating is mechanically induced and does not rely on differential pressure.

Applications

- The Neldisc triple eccentric disc valves are widely used in applications such as:
 - Liquids
 - Gases
 - Steam
- Pulpstocks both on control and shutoff services.

Reliable operation

Reliability, uninterrupted operation and freedom from routine maintenance are some of the cost-saving features this valve offers. The Neldisc L12 valve has a rugged body. Neither the forces in the pipeline nor thermal fluctuation have any effect on the operation or tightness of the valve. The rigid floating type stainless steel metal seat with triple-offset elliptical disc, offers a seating free of mechanical wear. The valve can handle pulp stocks up to 2.5% in control service and up to 4% in on-off service. This covers almost 100% of the conditions under which butterfly valves operate in the pulp and paper industry mill pipelines.

Reasonable spare valve stock

Since the Neldisc L12 is suitable for nearly all butterfly valve applications in the pulp and paper industry, the range of spare valves needed could be reduced to just one, a universal Neldisc. Greater interchangeability means smaller inventory investments.

Exploded view

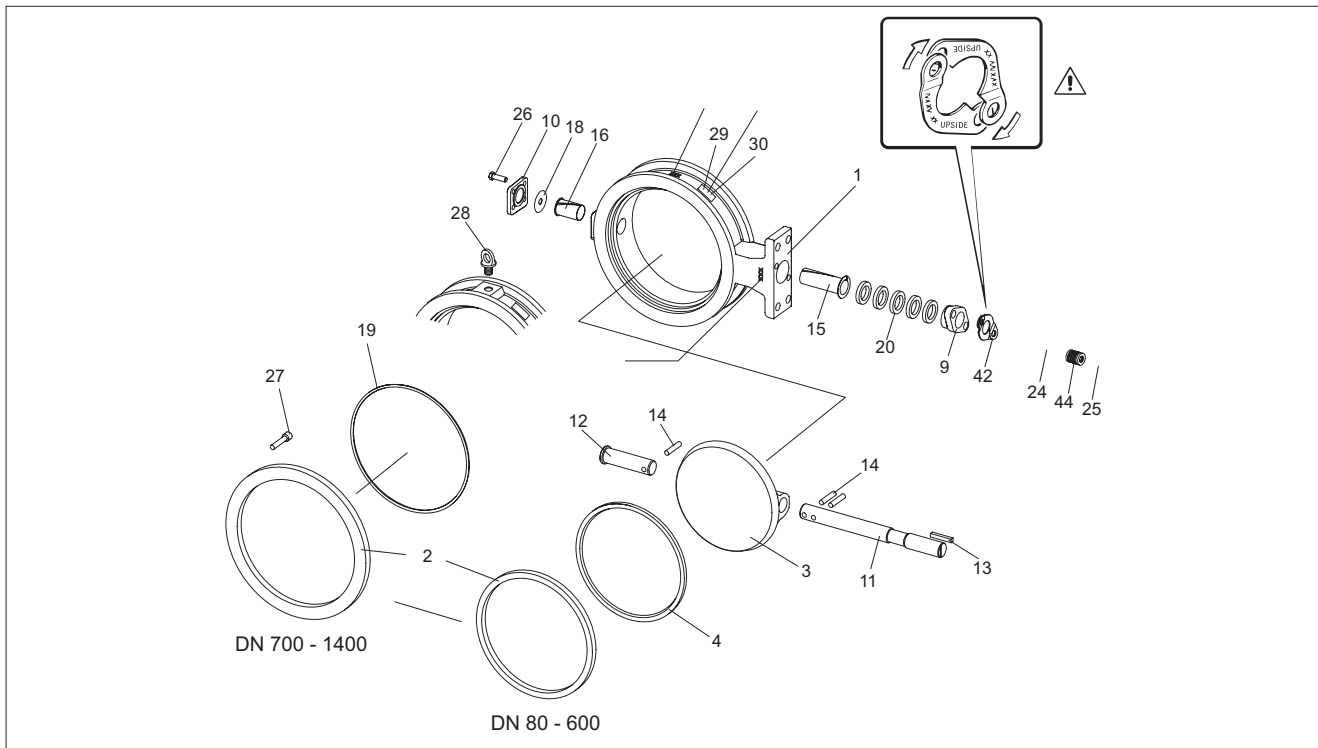

Parts list

Item	Qty	Part description	Material
1	1	BODY	Stainless steel
2	1	CLAMP RING	Stainless steel
3	1	DISC	Stainless steel
4	1	SEAT RING	Ni-Fe-base superalloy + Hard chrome DN80 - 600 Stainless steel + hard chrome DN700 - 1400
9	1	GLAND	Stainless steel
10	1	BLIND FLANGE	Stainless steel
11	1	DRIVE SHAFT	Stainless steel
12	1	SHAFT	Stainless steel
13	1	KEY	Stainless steel
14	3	PIN	Stainless steel
15	1	BEARING	PTFE on stainless steel net
16	1	BEARING	PTFE on stainless steel net
18	1	GASKET	Graphite
19	1	BODY SEAL, DN 1200 - 1400	Graphite
20	5	GLAND PACKING	PTFE / Graphite
24	2	STUD	Stainless steel
25	2	HEXAGON NUT	Stainless steel
26		HEXAGON SCREW	Stainless steel
27	2/4	HEXAGON SOCKET HEAD SCREW DN700 - 1400	Stainless steel
29	1	IDENTIFICATION PLATE	Stainless steel
42	2	RETAINING PLATE	Stainless steel
44		Disc Spring Stack	Electroless nickel plated spring steel (EN 10083-1.8159)

Seating principle

The disc of the valve is machined to close tolerances to create an elliptical shape similar to an oblique slice taken from a solid metal cone. When the valve is closed, the elliptical disc at the major axis displaces the seat ring outward, causing the seat ring to make contact with the disc at the minor axis. When the valve is opened, the contact is released and the seat ring returns to its original circular shape.

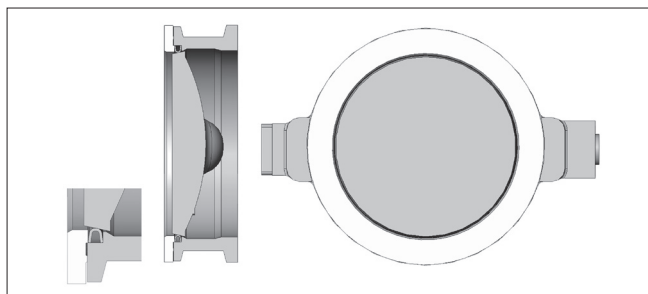

Technical specification

Type

Wafer-type, full-bore, metal-to-metal seated triple eccentric disc valve.

Body

DN 80 - 125 PN40/ASME 300 rated one-piece body.
 DN 150 - 600 PN25/ASME 150 rated one-piece body.
 DN 700 - 1400 PN25/ASME 150 rated body.

Suitable for fitting between flanges to:

ASME 150
 PN 10, 16, 25
 JIS 10.

Maximum differential pressure

Rated pressure differential for the trim:

DN 80 - 125 / 3" - 5"	$\Delta p_{\max} = 25 \text{ bar} / 363 \text{ psi}$
DN 150 / 6"	$\Delta p_{\max} = 25 \text{ bar} / 363 \text{ psi}$
DN 200 / 8"	$\Delta p_{\max} = 20 \text{ bar} / 290 \text{ psi}$
DN 250 - 1000 / 10" - 40"	$\Delta p_{\max} = 10 \text{ bar} / 145 \text{ psi}$
DN 1200 - 1400 / 48" - 56"	$\Delta p_{\max} = 6 \text{ bar} / 87 \text{ psi}$

Face-to-face dimensions

Dimensions according to:

EN 558 - 2 Serie 20
 ISO 5752 (Series 20)
 API 609 low-pressure (Class 150)
 API 609 high-pressure (Class 150)
 except DN 350
 BS 5155 (Class 150 medium)
 SSG 1036.

C_v values and flow resistance coefficients

Valve size DN / inch	C _v 90°	ζ 90°
80 / 3"	245	1.2
100 / 4"	450	1.2
125 / 5"	840	0.85
150 / 6"	1500	0.56
200 / 8"	3050	0.41
250 / 10"	5200	0.30
300 / 12"	7700	0.28
350 / 14"	11000	0.30
400 / 16"	14300	0.32
500 / 20"	22900	0.34
600 / 24"	32400	0.33
700 / 28"	41600	0.33
800 / 32"	56600	0.33
900 / 36"	70800	0.33
1000 / 40"	87800	0.33
1200 / 48"	129000	0.33
1400 / 56"	177000	0.33

Sizes

DN 80, 100, 125, 150, 200, 250, 300, 350, 400, 500, 600, 700, 800, 900, 1000, 1200, 1400.
 3", 4", 5", 6", 8", 10", 12", 14", 16", 20", 24", 28", 32", 36", 40", 48", 56".

Testing

Valve testing: Each valve undergoes a shell test and a seat test.
 The shell test pressure is 1.5 x PN.
 The seat test pressure is 1.1 x PN.
 The test medium is inhibited water.

Valve tightness: Bidirectional ISO 5208 Rate D.
 10 x ISO 5208 rate D with RH hand lever

Temperature range: -40...+260 °C / -60...+500 °F.

Standard materials

Body and disc: Stainless steel ASTM A 351 gr.
 CF8M (type AISI 316).

Shaft, pins and key: Duplex 1.4460 / 1.4462.

Seat: Stainless steel ASTM B 424
 (Incoloy 825): DN80 - 600.
 EN 10083 - 14418: DN700 - 1000.

Bearings: Carbon-filled PTFE reinforced
 with stainless steel net. Metal bearings as
 an option DN 700 - 1400.

Gland packing: PTFE or Graphite

Gaskets: Graphite.

Pressure/temperature ratings, CF8M

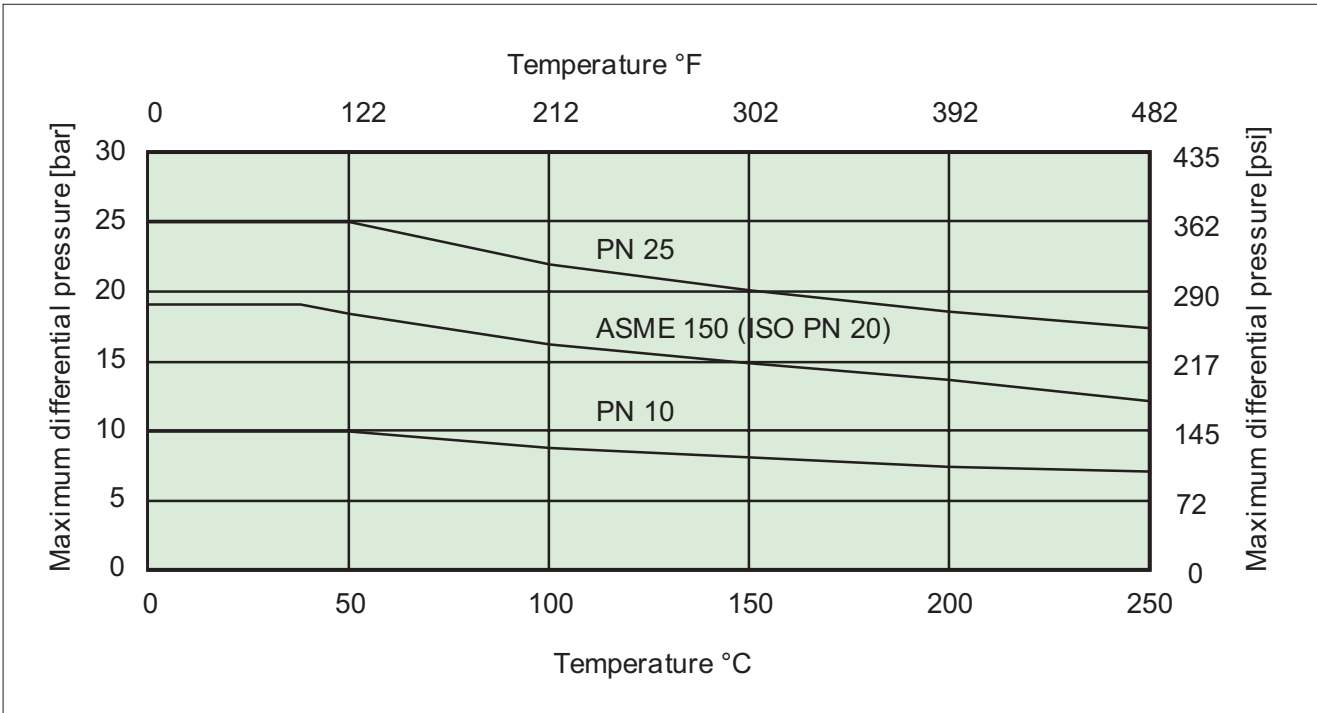

Dimensions

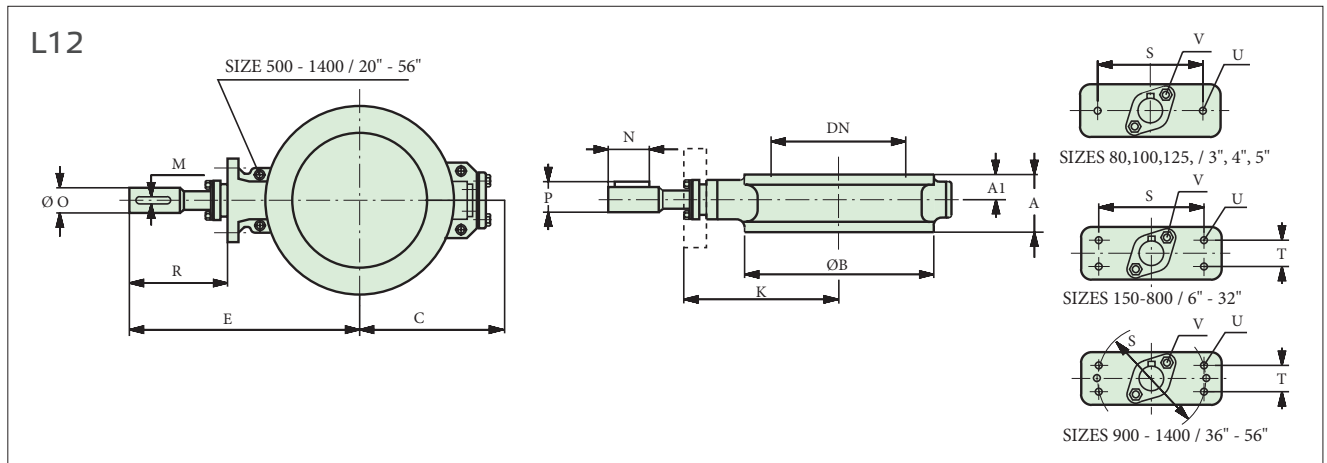

Type	DN	Dimensions, mm													U	V	kg	Δps bar	Δp70° bar
		A	A1	ØB	C	E	K	S	T	O	R	M	P	N					
L12A 80	80	47	20	132	80	213	190	70	-	15	105	4.763	17	25	M10	M8	4	25	8
L12A 100	100	52	25	160	100	256	220	90	-	20	125	4.763	22.2	35	M12	M8	5	25	10.7
L12A 125	125	56	27	180	115	269	235	90	-	20	125	4.763	22.2	35	M12	M8	7	25	5.4
L12A 150	150	56	28	216	130	305	270	110	32	20	125	4.763	22.2	35	M12	M8	11	25	3.1
L12A 200	200	61	27	272	160	346	300	110	32	25	136	6.35	27.8	46	M12	M10	16	20	2.8
L12A 250	250	68	32	327	200	376	330	130	32	25	156	6.35	27.8	46	M12	M10	27	10	1.5
L12A 300	300	78	34	373	270	409	360	130	32	30	159	6.35	32.9	51	M12	M10	40	10	1.3
L12A 350	350	78	34	416	310	473	415	160	40	35	178	9.525	39.1	58	M16	M10	45	10	1.5
L12A 400	400	102	45	480	330	513	445	160	40	40	188	9.525	44.2	68	M16	M10	75	10	1.3
L12A 500	500	127	63.5	590	420	610	520	160	55	50	230	12.7	55.5	90	M20	M14	120	10	1.5
L12A 600	600	154	77	690	480	739	620	230	90	70	299	19.05	78.2	119	M24	M16	220	10	2.2
L12B 700	700	165	65	800	536	829	710	230	90	70	299	19.05	78.2	119	M24	M16	331	10	1.5
L12B 800	800	190	80	900	622	937	791	230	90	85	326	22.225	94.7	146	M24	M16	489	10	1.8
L12B 900	900	203	91.4	1000	678	1058	902	330	120	95	376	22.225	104.8	156	M30	M20	651	10	1.7
L12B 1000	1000	216	95	1110	728	1108	952	330	120	95	376	22.225	104.8	156	M30	M20	805	10	1.2
L12B 1200	1200	254	108	1330	855	1250	1080	330	120	105	400	25.4	116.2	170	M30	M20	1200	6	1
L12B 1400	1400	279	118	1540	950	1395	1200	360	135	120	455	31.75	133.8	195	M30	M20	1900	6	1

Type	SIZE	Dimensions, inch													U	V	lbs	Δps psi	Δp70° psi
		A	A1	ØB	C	E	K	S	T	O	R	M	P	N					
L12A 80	3	1.85	0.79	5.20	3.15	8.39	7.48	2.76	-	0.59	4.13	0.19	0.67	0.98	M10	M8	8.8	363	116
L12A 100	4	2.05	0.98	6.30	3.94	10.08	8.66	3.54	-	0.79	4.92	0.19	0.87	1.38	M12	M8	11	363	155
L12A 125	5	2.20	1.06	7.48	4.53	10.59	9.25	3.54	-	0.79	4.92	0.19	0.87	1.38	M12	M8	15.4	363	78
L12A 150	6	2.20	1.10	8.50	5.12	12.01	10.63	4.33	1.26	0.79	4.92	0.19	0.87	1.38	M12	M8	24.2	363	45
L12A 200	8	2.40	1.06	10.71	6.30	13.62	11.81	4.33	1.26	0.98	5.35	0.25	1.09	1.81	M12	M10	35.2	290	41
L12A 250	10	2.68	1.26	12.87	7.87	14.80	12.99	5.12	1.26	0.98	6.14	0.25	1.09	1.81	M12	M10	59.4	145	22
L12A 300	12	3.07	1.34	14.69	10.63	16.10	14.17	5.12	1.26	1.18	6.26	0.25	1.30	2.01	M12	M10	88	145	19
L12A 350	14	3.07	1.34	16.38	12.20	18.62	16.34	6.30	1.57	1.38	7.01	0.38	1.54	2.28	M16	M10	99	145	22
L12A 400	16	4.02	1.77	18.90	12.99	20.20	17.52	6.30	1.57	1.57	7.40	0.38	1.74	2.68	M16	M10	165	145	19
L12A 500	20	5.00	2.50	23.23	16.54	24.02	20.47	6.30	2.17	1.97	9.06	0.50	2.19	3.54	M20	M14	264	145	22
L12A 600	24	6.06	3.03	27.17	18.90	29.09	24.41	9.06	3.54	2.76	11.77	0.75	3.08	4.69	M24	M16	484	145	32
L12B 700	28	6.5	2.55	31.5	21.1	32.64	27.95	9.05	3.54	2.76	11.77	0.75	3.08	4.68	M24	M16	730	145	22
L12B 800	32	7.48	3.15	35.4	24.5	36.89	31.14	9.05	3.54	3.35	12.83	0.875	3.72	5.75	M24	M16	1078	145	26
L12B 900	36	8	3.6	39.4	26.7	41.65	35.51	13	4.72	3.74	14.80	0.875	4.13	6.14	M30	M20	1435	145	25
L12B 1000	40	8.5	3.74	43.7	28.7	43.62	37.48	13	4.72	3.74	14.80	0.875	4.13	6.14	M30	M20	1774	145	17
L12B 1200	48	10.00	4.25	52.36	33.66	49.21	42.52	12.99	4.72	4.13	15.75	1.00	4.57	6.69	M30	M20	2640	87	14.5
L12B 1400	56	10.98	4.65	60.63	37.40	54.92	47.24	14.17	5.31	4.72	17.91	1.25	5.27	7.68	M30	M20	4180	87	14.5

Δps = max. shut-off pressure, bar/psi, allowed by valve's mechanical strength.

Δp70° = max. pressure differential, bar/psi, across 70° open valve allowed by valve's mechanical strength.

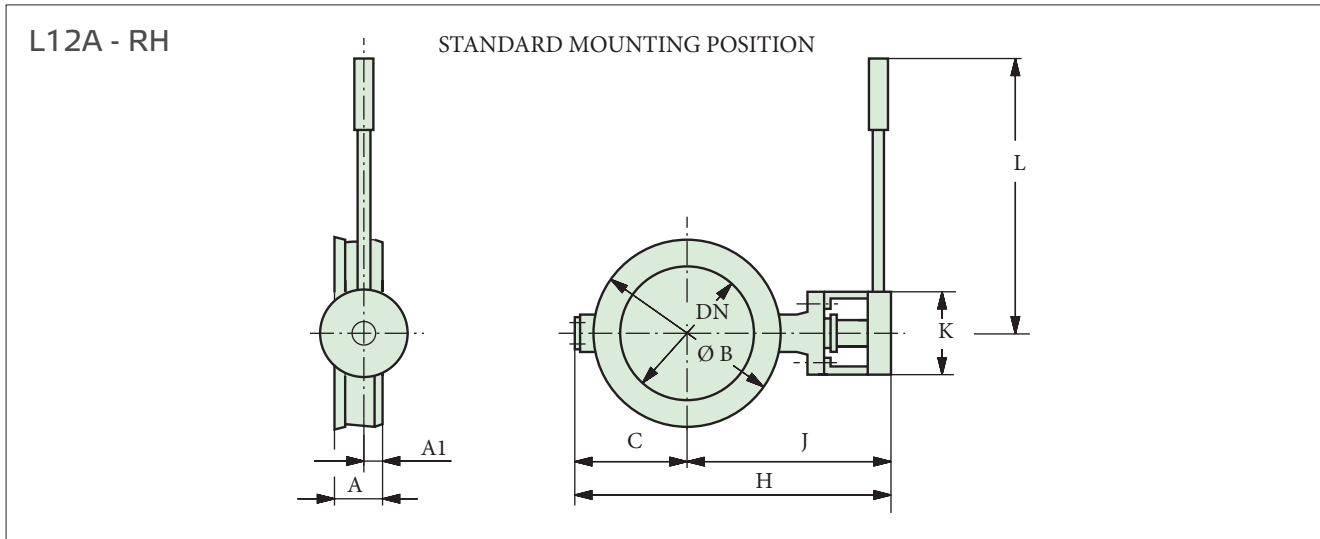

	Dimensions, mm									kg	Dimensions, inch									lbs
	DN	A	A1	øB	C	H	J	K	L		Size	A	A1	øB	C	H	J	K	L	
L12A 80-RH415	80	47	20	132	80	293	213	100	400	5	3	1.85	0.79	5.20	3.15	13.39	8.39	3.94	15.75	11
L12A 100-RH420	100	52	25	160	100	356	256	100	400	6	4	2.05	0.98	6.30	3.94	14.02	10.08	3.94	15.75	13
L12A 150-RH420	125	56	27	190	115	384	269	100	400	8	5	2.20	1.06	7.48	4.53	15.12	10.59	3.94	15.75	18
L12A 150-RH520	150	56	28	216	130	435	305	130	520	12	6	2.20	1.10	8.50	5.12	17.13	12.01	5.12	20.47	26

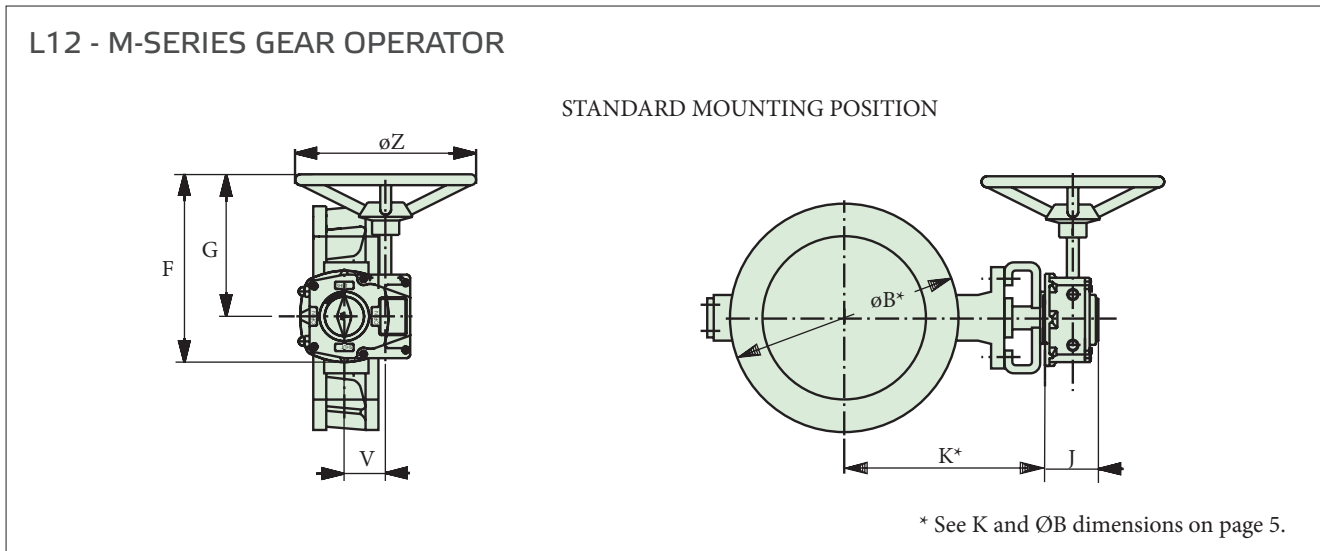

Type	Dimensions, mm					kg
	F	G	J	V	ØZ	
M07	241	185	65	52	160	4
M10	241	185	65	52	200	4
M12	304	235	88	71	315	10
M14	405	305	93	86	400	18
M15	456	346	102	105	500	26
M16	530	387	124	130	600	37

Type	Dimensions, inch					lbs
	F	G	J	V	ØZ	
M07	9.49	7.28	2.56	2.05	6.30	9
M10	9.49	7.28	2.56	2.05	7.87	9
M12	11.97	9.25	3.46	2.80	12.40	22
M14	15.94	12.01	3.66	3.39	15.75	40
M15	17.95	13.62	4.02	4.13	19.69	57
M16	20.87	15.24	4.88	5.12	23.62	81

VALVE + PNEUMATIC ACTUATOR / B1C / B1J / B1JA

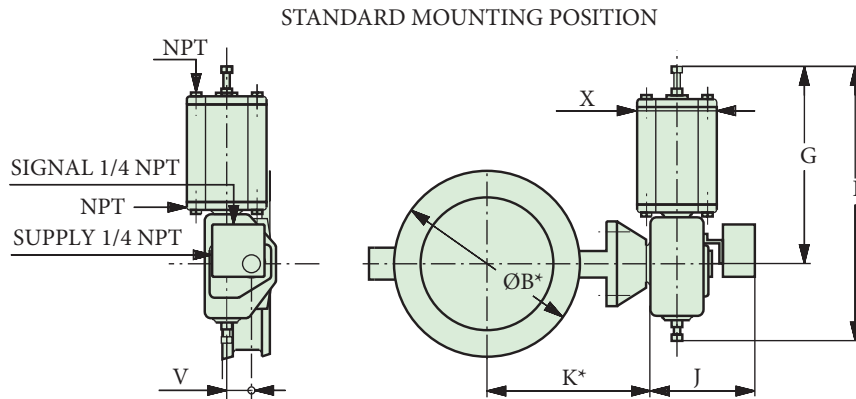

*) see dimensions ØB and K on table page 5.

Type	Dimensions, mm					NPT	kg
	X	G	F	V	J		
B1C6	90	260	400	36	283	1/4	4.2
B1C9	110	315	455	43	279	1/4	9.6
B1C11	135	375	540	51	290	3/8	16
B1C13	175	445	635	65	316	3/8	31
B1C17	215	545	770	78	351	1/2	54
B1C20	215	575	840	97	385	1/2	73
B1C25	265	710	1040	121	448	1/2	131
B1C32	395	910	1330	153	525	3/4	256
B1C40	505	1150	1660	194	595	3/4	446
B1C50	610	1350	1970	242	690	1	830

Type	Dimensions, mm					NPT	kg
	X	G	F	V	J		
B1J, B1JA6	110	368	485	36	273	3/8	13
B1J, B1JA8	135	420	560	43	279	3/8	17
B1J, B1JA10	175	490	650	51	290	3/8	30
B1J, B1JA12	215	620	800	65	316	1/2	57
B1J, B1JA16	265	760	990	78	351	1/2	100
B1J, B1JA20	395	935	1200	97	358	3/4	175
B1J, B1JA25	505	1200	1530	121	448	3/4	350
B1J, B1JA32	540	1410	1830	153	525	1	671
B1J/B1JA40	724	1578	2095	194	580	1	1100

Type	Dimensions, inch					NPT	lbs
	X	G	F	V	J		
B1C6	3.54	10.24	15.75	1.42	11.14	1/4	9
B1C9	4.33	12.40	17.91	1.69	10.98	1/4	21
B1C11	5.31	14.76	21.26	2.01	11.42	3/8	35
B1C13	6.89	17.52	25.00	2.56	12.44	3/8	68
B1C17	8.46	21.46	30.31	3.07	13.82	1/2	119
B1C20	8.46	22.64	33.07	3.82	15.16	1/2	161
B1C25	10.43	27.95	40.94	4.76	17.64	1/2	289
B1C32	15.55	35.83	52.36	6.02	20.67	3/4	564
B1C40	19.88	45.28	65.35	7.64	23.43	3/4	983
B1C50	24.02	53.15	77.56	9.53	27.17	1	1829

Type	Dimensions, inch					NPT	lbs
	X	G	F	V	J		
B1J, B1JA6	4.33	14.49	19.09	1.42	10.75	3/8	28
B1J, B1JA8	5.31	16.54	22.05	1.69	10.98	3/8	37
B1J, B1JA10	6.89	19.29	25.59	2.01	11.42	3/8	66
B1J, B1JA12	8.46	24.41	31.50	2.56	12.44	1/2	126
B1J, B1JA16	10.43	29.92	38.98	3.07	13.82	1/2	220
B1J, B1JA20	15.55	36.81	47.24	3.82	14.09	3/4	386
B1J, B1JA25	19.88	47.24	60.24	4.76	17.64	3/4	771
B1J, B1JA32	21.26	55.51	72.05	6.02	20.67	1	1479
B1J/B1JA40	28.50	62.13	84.48	7.64	22.83	1	2424

How to order

Example

1	2	3	4	5	6
L12	A	150	A	A	-

1	Product series/design
L12	Face-to-face length according to EN 558 Series 20, API 609, BS 5155 and SSG 1036

2	Pressure ratings
A	Body rating PN 50/ASME 300 DN 80-125 PN 25/ASME 150 DN 150-600
	DN 80-125 $\Delta p_{max} = 25 \text{ bar} / 363 \text{ psi}$, welded clamp ring
	DN 150 $\Delta p_{max} = 25 \text{ bar} / 363 \text{ psi}$, welded clamp ring
	DN 200 $\Delta p_{max} = 20 \text{ bar} / 290 \text{ psi}$, welded clamp ring
	DN 250-600 $\Delta p_{max} = 10 \text{ bar} / 145 \text{ psi}$, welded clamp ring
B	Body rating DN 700-1400 PN25/ASME 150
	DN 700-1000 $\Delta p_{max} = 10 \text{ bar} / 145 \text{ psi}$, bolted clamp ring
	DN 1200-1400 $\Delta p_{max} = 6 \text{ bar} / 87 \text{ psi}$, bolted clamp ring

3	Diameter nominal
	080, 100, 125, 150, 200, 250, 300, 350, 400, 500, 600, 700, 800, 900, 1000, 1200, 1400

4	Body, disc and shaft material
A	Body and disc: stainless steel ASTM A351 CF8M Shaft: Duplex 1.4460 / 1.4462

5	Seat material
A	Stainless steel ASTM B424 (Incoloy 825 + Hcr) DN 80-600
B	W.no. 1.4418 + hard chrome DN 700-1400

6	Gland packing
-	DN 80-600 PTFE standard packing (DN 700-1400 always with the sign "T")
T	Live loaded PTFE V-ring packing with disc springs sets
G	Live loaded graphite packing with disc springs sets

Subject to change without prior notice.

Neles, Neles Easyflow, Jamesbury, Stonel, Valvcon and Flowrox, and certain other trademarks, are either registered trademarks or trademarks of Valmet Oyj or its subsidiaries in the United States and/or in other countries.

Valmet Flow Control Oy

Vanha Porvoontie 229, 01380 Vantaa, Finland.

Tel. +358 10 417 5000.

www.valmet.com/flowcontrol

